

Handling and Installation
Excerpt
from
PRYSMIAN'S
*WIRE AND CABLE
ENGINEERING GUIDE*

RECEIVING / HANDLING CABLE

Underground cable (power cable) represents a significant investment in an underground distribution (UD) system. To get the most benefit from this investment, the purchaser should specify high quality cable and have a complete visual inspection program that will help identify any cable that is damaged during transit. Any unacceptable cable is then returned to the manufacturer instead of being installed. Identifying and rejecting damaged cable improves the reliability and life expectancy of the underground system.

Receipt of Cable Reels

Upon receiving the cable shipments, the purchaser should conduct an acceptance inspection. A cable acceptance inspection involves several simple and inexpensive steps that can yield big dividends. The cable acceptance inspection should consist of the following steps:

1. Visually inspect for shipment damage

Visually inspect cable reels for any damage that may have occurred in transit. Be particularly alert for cable damage if:

- a. In general if a reel is laying flat on its side, particularly if it is a large conductor size, e.g. 500 kcm, 750 kcm, 1000 kcm, etc.
- b. Several reels are stacked
- c. Other freight is stacked on the reel
- d. Nails have been driven into the flange to secure blocking
- e. A reel flange is damaged
- f. A cable covering is removed, stained, or damaged
- g. A cable end seal is removed or damaged (**a damaged or missing end seal means that moisture may have entered the cable**)
- h. A reel has been dropped (hidden damage likely)

2. Inspect reel tags

Visually check each reel to insure that it has the proper tags and labels as described in

the specifications. The reel should contain the following minimum information:

- a. Purchaser's name and address
- b. Purchase order number
- c. Conductor size and type
- d. Insulation thickness and type
- e. Jacket type
- f. Amount of cable on reel
- g. Beginning and ending sequential footage numbers that are marked on jacket (if specified)

Verify that the cable description, reel size, and cable footage match that specified. Any missing information should be obtained from the manufacturer.

3. Check dimensional tolerances

Make a simple measurement of the basic cable dimensions on one reel of each size of cable in a shipment to verify that the cable's dimension meet the specification.

Handling of Cable Reels

When moving cable reels, care should be taken to insure that material handling equipment does not come in contact with cable surfaces or with protective covering on the reel. **Under no circumstances should cable reels be dropped from any height, or be allowed to roll uncontrolled.** Whenever possible, cable reels should be moved or lifted using the method shown at the end of the document.

1. For cranes, booms, or other overhead lifting equipment, a heavy steel arbor or suitable heavy rod or pipe should be inserted through the reel hubs so that the cable reel can then be lifted by slings utilizing spreader bars or a lifting yoke. This method will insure that sling pressure against a reel flange, tipping of the reel, slipping of the sling, and other unbalanced situation will be minimized.
2. When lifting reels by fork truck type equipment, reels should only be lifted from the sides, and only if the blades of the fork truck are long enough to cradle both

flanges. This method will ensure that the lift pressure is equally distributed on both flanges and not on the cable itself.

3. Rolling reels containing cables should be kept to a minimum; if rolling is necessary, reels should always be rolled in the direction indicated by the “arrows” on the sides of the reel flanges or in the opposite direction to which the cable is wrapped onto the reel. This procedure will prevent loosening of the cable wraps on the reel which may result in problems during installation.
4. The path over which the cable reels are to be rolled must be clear of any debris, which might damage the cable if the reels were to roll over it. Cable reels unloaded down ramps should be rolled in the direction of the “Roll This Way” arrow and lowered in a controlled manner. The ramps must be of a gradual incline, spaced parallel and wide enough to ensure contact at all times with both reel flanges during unloading.

Storage of Cable Reels

It is not recommended to store cable reels on their sides.

Where possible, cable reels are to be stored indoors on a hard, dry surface to prevent deterioration of the reels and possible ingress of moisture into the cables.

Cable reels stored outdoors must be supported off the ground and covered with a suitable weatherproof material. The reel supports should be at least twice the width of the reel flange, long enough to provide adequate load bearing surface (to prevent sinking), and high enough to prevent the reel from sitting in free standing water in the event of heavy rainfall. All reel supports must be positioned under each reel flange, and to prevent free rolling each reel should be chocked between the reel flange and the support at opposite sides of the flange.

All cable reels should be stored in such a manner allowing easy access for lifting and moving, away from construction activities, falling or lying objects, sources of high heat, open flames, chemicals or petroleum products, etc. that may come in contact with the cable and

cause damage. The use of fencing or other barriers to protect cables and reels against damage by vehicles or other equipment moving about the storage area is highly recommended.

If the cable is to be stored on reels for future use after the factory applied endcaps are removed, the exposed cable ends **MUST** be re-sealed using properly applied weatherproof endcaps or by taping the ends with a tape/mastic designed specifically to prevent the entrance of moisture into the cable. Tapes such as PVC or Duct Tape are not suitable for preventing the entrance of moisture. Loose cable ends on the reels must be securely re-fastened to the reel flange and should not be allowed to lie on the ground.

For prolonged storage of (wooden) reels, especially in an outdoor environment, reels and endcaps should be inspected periodically. A monthly inspection is initially adequate but consideration should be given to increasing this frequency as the storage time lengthens – the increase in frequency will depend on the rate of deterioration. Wooden reels will deteriorate over time and sealed endcaps will lose their effectiveness. The rates of deterioration will vary with the environment in which the cable and reel are stored. Severely deteriorated reels will make it difficult if not impossible to utilize or even move and in some cases can result in damage to the cable during movement or cable pay off.

NOTE: If a particular method of shipping is required (i.e. shipment to job site, etc.), the manufacturer must be notified of the special shipping requirements.

INSTALLATION SUGGESTIONS

The information outlined below is offered as a general guide for the installation of unshielded and shielded cables, jacketed cables rated 600 to 35,000 volts in conduit, underground ducts, racks, trays or direct buried.

Precautions Prior to Pulling Cable

Temperature Considerations

Low temperatures create handling and pulling difficulties of varying degrees depending on cable construction and installation location. Situations like this require special consideration

of the cold induced stiffness of the cable when choosing radii and number of bends in the proposed installation. Most cables can be safely handled if not subjected to temperatures lower than -10°C (14°F) in the twenty-four (24) hour period preceding the pulling and bending of the cable. If temperatures are expected to fall below this value during the preceding 24 hour period, provisions should be made to move the cable to a warm storage area or provide localized shelter and heating. The cable should be exposed to a temperature of 15°C (60°F) for 24 hours to ensure complete warm-up of the cable. Pulling eyes, if necessary, should be installed at this time. During cold weather installations, cable should be pulled more slowly and trained in place the same day it is removed from the warm storage area. The cable should not be impacted, dropped, kinked, or bent sharply in cold temperatures.

Duct Sizing

Select conduit or duct size in such a way that the difference between the hoop (circumscribing) diameter of the cable(s) and the inside diameter of the conduit or duct, will not be less than 1/2" at any point. As applicable, check that the cross-sectional area of the cable will not be more than the percentage of the interior cross-sectional area of the conduit recommended by the National Electric Code. Where long or difficult pulls are anticipated, the use of larger conduits, ducts or additional pull boxes or manholes should be considered.

Jam Ratio

When three cables are pulled in parallel in a conduit, there is a possibility of wedging action developing in bends. The cables changing from a triangular configuration to a cradled configuration as they are pulled in through the bend cause this. This change in configuration will force the two outer cables further apart. If the conduit diameter is too small to accommodate this wider configuration, the cables will become jammed in the bend. To predict this phenomenon, the jam ratio should be checked. The jam ratio is defined as the ratio of the inside diameter of the duct to the cable diameter, i.e.

$$J = \frac{D}{d}$$

Where:

- J = Jam ratio
- D = Inside diameter of duct (in.)
- d = Outside diameter of cable (in.)

When the jam ratio is calculated, the probable cable configuration in the conduit can be determined. A listing of the probable configurations is as follows:

Jam Ratio	Cable Configuration
J < 2.4	Triangular
2.4 < J < 2.6	More likely triangular
2.6 < J < 2.8	Either triangular or cradled
2.8 < J < 3.0	More likely cradled
J > 3.0	Cradled

Experience has shown that cable jamming is more likely between J = 2.8 and J = 3.1. This is particularly true if the sidewall bearing pressure (SWBP) in a bend exceeds 1000 pounds/foot.

Cable Clearance

In applications where the National Electrical Code (NEC) limits on conduit fill do not apply, it is necessary to calculate the clearance between the cable(s) and conduit to ensure that the cables can be pulled through the conduit. It is recommended that the calculated clearance be not less than 0.5 inches. A lesser clearance, as low as 0.25 inches, may be acceptable for essentially straight pulls. The clearance should also be adequate to accommodate the pulling eye or cable grip, which will be employed for the cable pull. The following formulas can be used to calculate the cable clearance for a single cable pull and for a three-cable pull. (NOTE: In order to allow for variations in cable and duct dimensions and ovality of the duct at bends, the nominal cable diameter "d" has been increased by five percent).

- a) Single Cable Pull

$$C = D - 1.05 \cdot d$$

- b) Three Cable Pull (triangular configuration)

$$C = \frac{D}{2} - 1.366(1.05 \cdot d) + \frac{(D - 1.05 \cdot d)}{2} \cdot \sqrt{1 - \left[\frac{1.05 \cdot d}{(D - 1.05 \cdot d)} \right]^2}$$

Where:

- C = Cable clearance (in)
- D = Inside diameter of duct (in)

d = Outside diameter of cable (in)

In applications where the National Electric Code (NEC) is binding, the below table identifies the most common scenarios regarding the fill ratio of several cable configurations in various duct sizes.

CONDUCTOR FILL PER NEC CODE								
DUCT SIZES (inches)	1 CONDUCTOR (53% Fill Ratio)		2 CONDUCTORS (31% Fill Ratio)		3 CONDUCTORS (40% Fill Ratio)		4 CONDUCTORS (40% Fill Ratio)	
	Area (in ²)	d _{max} (in)	Area (in ²)	d _{max} (in)	Area (in ²)	d _{max} (in)	Area (in ²)	d _{max} (in)
	1/2	0.16	0.453	0.09	0.245	0.12	0.227	0.12
3/4	0.28	0.6	0.16	0.324	0.21	0.301	0.21	0.261
1	0.46	0.764	0.27	0.413	0.34	0.383	0.34	0.332
1 1/4	0.80	1.005	0.47	0.543	0.60	0.504	0.60	0.436
1 1/2	1.08	1.172	0.63	0.634	0.82	0.588	0.82	0.509
2	1.78	1.505	1.04	0.814	1.34	0.755	1.34	0.654
2 1/2	2.54	1.797	1.48	0.972	1.92	0.902	1.92	0.781
3	3.91	2.234	2.26	1.208	2.95	1.12	2.95	0.97
3 1/2	5.25	2.583	3.07	1.397	3.96	1.296	3.96	1.122
4	6.74	2.931	3.94	1.585	5.09	1.47	5.09	1.273
5	10.60	3.674	6.20	1.987	8.00	1.843	8.00	1.596
6	15.31	4.415	8.96	2.388	11.56	2.215	11.56	1.918

NOTE: “d_{max}(in)” is the maximum single conductor diameter that will satisfy the above requirements. “Area (in²)” is the area of the conductor(s). Ground wires have not been considered in the above table. However, the NEC does require that “Equipment grounding or bonding conductors, where installed, shall be included when calculating conduit or tubing fill. The actual dimensions of the equipment grounding or bonding conductor (insulated or bare) shall be used in the calculation.”

Where a calculation must be made to comply with the NEC fill ratio requirements, the following formula may be used:

$$FR = [N_{PC} \times (PC_D \div 2)^2 + N_{GC} \times (GC_D \div 2)^2] \div (C_D \div 2)^2$$

Where:

- FR = Fill Ratio (%)
- N_{PC} = Number of Phase Conductors with the same diameter
- PC_D = Diameter of Phase Conductor (in.)
- N_{GC} = Number of Ground Conductors with the same diameter
- GC_D = Diameter of Ground Conductor (in.)
- C_D = Diameter of Conduit or Duct (in.)

Minimum Bending Radius (Static Conditions)

The minimum values for the radii to which such cables may be bent for permanent training can be determined by the following formula:

$$MBR = OD \times M$$

Where:

- MBR = Minimum radius of bend (in)
- OD = Outside diameter of cable (in)
- M = Diameter multiplier (See tables on following page(s))

The above calculation is for STATIC conditions ONLY. Reference the DYNAMIC Conditions

section (as follows) as well as the Sidewall Bearing Pressure section for the minimum bending radius of cable in motion.

Minimum Bending Radius (Dynamic Conditions)

The minimum values for the radii to which such cables may be bent while being pulled into an installation and while under tension can be determined by the formula following this paragraph. This value will greatly depend on the tension the cable is experiencing as it exits the bend in question. For instance the greater the exiting tension, the greater the minimum-bending radius will be for the cable.

$$MBR = (T_e \div SWBP) \times 12 \text{ (inches)}$$

Where:

- MBR = Minimum radius of bend (in.)
- T_e = Tension as cable exits the bend (pounds•force)
- SWBP = Maximum allowable Sidewall Bearing Pressure (pounds•force per foot of bend radius)

Cable Training (Offset bending)

Use the following formula to calculate the minimum distance required for permanent cable training (offset bending) in a manhole:

$$L = \sqrt{S(4R - S)}$$

Where:

- L = Minimum distance required (in)
- S = Offset (in)
- R = Bending radius to cable centerline (in.)

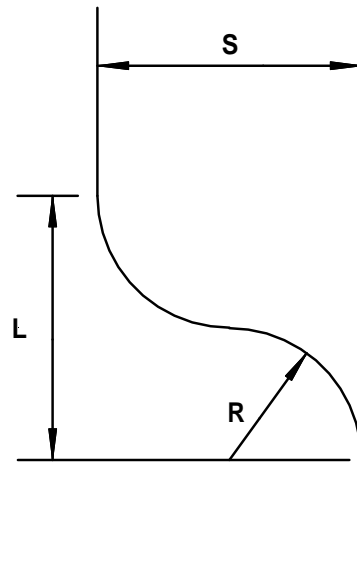

Allow an appropriate length of straight cable at both ends of the offset bend.

Power and Control Cables without Metallic Shielding or Armor

Insulation Thickness (mils)	Overall Diameter of Cable (inches)		
	1.000 and Less	1.001 to 2.000	2.001 and Over
	Minimum Bending Radius as a Multiple of Cable Diameter		
155 and less	4	5	6
156 to 310	5	6	7
310 and over	-----	7	8

NOTE 1: In all cases, the highest applicable multiplier should be used. The calculated minimum bend radius (applicable multiplier x outside diameter of cable) refers to the inner surface of the bent cable, and not the axis (centerline) of the cable conduit.

NOTE 2: For assembled cables (“plexed”) use the thickest of the insulations of the cables within the assembly and the diameter of the largest single cable within the cable assembly to determine the multiplier, then apply that multiplier to the diameter of the overall assembly.

NOTE 3: The minimum values for the radii to which cables may be bent during installation may not apply to conduit bends, sheaves or other curved surfaces around which the cable may be pulled under tension while being installed. Larger radii bends may be required for such conditions. (See “Precautions During Cable Pulling” in the “Sidewall Bearing Pressure” section).

Power and Control Cables with Metallic Shielding or Armor

Cable Type	Minimum Bending Radius For Single Conductors	Minimum Bending Radius For Multiple Conductors †
Interlocked and Polymeric Armor (without shielded conductor)	7	7
Interlocked Armor and Polymeric Armor (with shielded conductor)	12	7
Wire Armored Cable	12	12
Metallic Tape Shielded Cable	12	7
Metallic Fine Wire Shield	12	7
Concentric Neutral Wire Shielded Cable	8	5
Lead Sheath Cable	12	7
LC Shielded Cable	12	7

† Use the larger of the two minimum bending radii when considering the minimum-bending radius for multiple conductors.

NOTE 1: To obtain the minimum-bending radius, multiply the diameter of the cable (or cable assembly) by the factor in the above table.

NOTE 2: These limits may not be suitable for conduit bends, sheaves or other curved surfaces around which the cable may be pulled under tension while being installed due to sidewall bearing pressure limits of the cable. The minimum radius specified refers to the inner radius of the cable bend and not to the axis of the cable.

Clearing Duct

Using a plug approximately the same diameter as the inside of the duct, clear all burrs and obstructions in the duct or conduit by pulling the plug through the structure. Follow with a wire brush and swab to clean and remove foreign matter from the duct. Smooth, burr-free duct interiors are important in preventing abrasion damage to the cable jacket during pulling.

Trench for Direct Burial

The trench should be cleared of all sharp stone, glass, metal or wood debris, which could damage cable jacket during or after cable installation. The trench bottom should be uniformly covered with a layer of soil or sand that has been screened through a medium-to-fine mesh screen to remove all larger stones or other material, to provide a smooth, soft bedding for the cable(s). In urban areas or where a great

deal of digging and/or excavating occurs, it is preferable to lay a protective covering on the fill approximately 6-8 inches above the cable to protect it and warn workmen of its presence. Under highways and railroad rights-of-way, it is preferable to install the cable in a pipe or conduit to give added mechanical protection.

Rack/Trays

The entire path that the cable will follow during pulling should be checked to make sure that the cable will ride free and clear of all obstructions, sharp edges or projections which might cause it to jam or be damaged in passage. In making this check, allowance must be made for the position the cable will assume when under tension and allowed to go slack.

Precautions During Cable Pulling

Cable Guides

To avoid abrasion and damage of the cable jacket when guiding the cable from the reel to the duct mouth or trench, all guides should be in the form of large diameter, smooth-surfaced, free-turning sheaves or rollers. If guide tubes or chutes must be used, they should have smooth, burr-free working surfaces, well flared entrances, largest possible bend radii, and be securely anchored so that cable passes smoothly over them. Cable tension going into the guides should be kept very low by mounting the cable reel in sturdy jacks, carefully leveling the reel shaft, and lubricating the reel arbor holes and shaft with grease. Braking of the reel should be done only to prevent reel over-run when the pull is slowed or stopped, or on steep downhill runs where cable weight is enough to overcome cable-duct friction.

Much of this information is equally true for rack or tray installations. In addition, the following points should be carefully observed when making such pulls:

1. Cable support rollers should be spaced close enough so that the cable's normal sag, even when under tension, will not result in its dragging on the tray.
2. The cable rollers or sheaves should be flanged or contoured so that the cable will

not ride off the end of the roller, or be "pinched" into a sheave contour diameter that is smaller than that of the cable.

3. Where rollers/sheaves are used to guide the cable through bends, it is essential that a sufficient number of them be used so as to support and guide the cable in a smooth curve of the desired radius from tangent point to tangent point. Otherwise, the cable will be "kinked" around the radius of each roller.

In direct-burial installations, the cable may be paid off the reel and laid into the trench as the reel is moved along the length of the trench. In such cases, the cable is simply laid on the bed of screened soil or sand.

Where the cable must be pulled through the trench, the preferred method is to support the cable on temporary rollers so that the cable does not drag over the soil or sand bed. If rollers are not available, sacks filled with very fine sand or other fine powdery material may be used as "pillows" to support the cable and keep it from dragging on the trench bed during pulling.

Cable Lubricant

Cable lubricants, or pulling lubricants, are used in conduit or duct to reduce pulling tensions on cables as well as abrasion damage to the cables. For polyethylene jackets, Prysmian recommends the use of water-based, Bentonite Clay lubricants. In general, pulling compounds that may contain oils or greases are to be avoided since such materials can adversely affect the cable jackets. Further, pulling lubricants containing micro-spheres or micro-balls should not be used for medium voltage cable installations. This lubricant is designed for low-tension pulls that are not representative of power cable pulls. Also, the micro-spheres tend to press (and become imbedded) into the jacket at the areas where high sidewall pressures are encountered.

Most commercially available pulling lubricants can be used with minimal concern for compatibility. However, some pulling lubricants react adversely with particular cable jacket compounds, resulting in degradation of the cable jacket. For this reason, Prysmian recommends the manufacturer of the pulling

lubricant be consulted in regards to the compatibility of the lubricant with any particular jacket compound. Prysmian does not endorse any particular name brand of lubricant or specific manufacturer, nor does Prysmian commonly perform compatibility testing of the lubricants, this is the responsibility of the lubricant manufacturer.

Pulling Eyes & Grips

Large size, heavy cables, or cables for pulls that are particularly long or contain numerous bends or changes in curvature, are best installed by means of a pulling eye attached to the conductor(s). The pulling eye is fastened directly to the conductor(s) on the end of the cable by soldering the copper conductors into a socket-type eye, or mechanically compressing the aluminum conductors into an aluminum eye. A solder wipe, heat-shrinkable tube or tape seal is applied over the eye-cable joint to provide a reliable weather-tight seal for the cable during cable pulling. On armored cables, the armor should be properly secured to the eye to insure cable integrity during pulling. Pulling eyes are usually installed at the factory, but, if required, can be assembled in the field.

Woven wire pulling grips or "baskets" - such as the Kellems grips - are often used to pull such cables, and are particularly suited for pulling smaller size/lower voltage cables, or where the pulls are relatively short and straightforward. * When such devices are to be used on Interlock Armored cables, special procedures must be followed to avoid damage to the cable or problems in making the pull. Since the Interlocked Armor may not be a tight, gripping fit on the cable core, the pulling grip may tend to stretch or elongate the sheath or armor in relation to the core, if the grip is not properly applied to the cable. The following method of preparing the cable and attaching the grip is therefore recommended:

1. Select the grip size that best fits the cable "core" (diameter under sheath or armor). Determine the length of the gripping portion of this grip.
2. Locate two points on the end of the cable. The first is 75% of the grip length from the end, the second is 100% of the grip length from the end.

3. Remove the sheath or armor (and outer jacket - if present) to the first mark. Do not damage or disturb the core. If necessary, secure the armor at the cut point with friction tape before cutting.
4. Apply four, 3 inch long, tight, half-lapped wrappings of friction tape: a) on end of core, b) on core to edge of sheath or armor, c) on jacket, sheath or armor to edge of same, and d) on jacket, sheath, or armor where last 3 inches of grip will be located.
5. If cable is likely to be exposed to moisture during the pull, seal the cut ends of the conductors with sealing mastic and vinyl tape, or heat-shrinkable cap(s).
6. Place the grip on the cable and snug it down tight by "milking" it from the cable end towards the end of the grip.
7. Secure the grip to the cable by clamping the back end of the grip to the cable with a steel, strap-type hose clamp (such as the "Punch-Lok" or "Band-It" types) or a robust steel wire serving, tightly applied.
8. Apply a tape wrapping over the clamp or serving to smooth it off to prevent "hang up" or drag during the pull.

CAUTION: The ends of cables pulled in this manner will not be completely sealed against the entry of water. If this is of concern, then properly applied pulling eyes should be used.

****NOTE: Since the compressive force applied by a pulling grip may disturb/damage the underlying cable, it is best to cut off the section immediately under the grip and approximately three (3) feet of cable behind the grip before splicing or terminating.***

Maximum Pulling Tensions

Pulling tensions for installing electrical cables should be maintained as low as possible to prevent damage to the cable. This may be accomplished through use of proper size ducts or conduits, avoiding long pulls, and avoiding runs containing sharp bends or an excessive number of changes in elevation. The following maximum allowable pulling tension must not be

exceeded when pulling cable by the method indicated.

A. Pulling Eye

For cables pulled with a pulling eye, the maximum tension should not be greater than the value calculated using the formula:

$$T_{\max} = \text{CTC} \times \text{CA} \times \text{N}$$

Where:

T_{\max} = Maximum pulling tension, (lbs)
CA = Conductor Area, (cmils)
N = Number of conductors being pulled
CTC = Conductor Tension Constant

For CTC with aluminum compression eyes or bolts use:

0.011 - Copper conductor
0.008 - Aluminum Stranded conductor
0.006 - Aluminum Solid conductor

For CTC with filled eyes or bolts (solder for copper and epoxy for aluminum) use:

0.013 - Copper conductor
0.011 - Aluminum Stranded conductor
0.008 - Aluminum Solid conductor

NOTE: Do not consider area of neutral or grounding conductors in cable(s) when calculating maximum pulling tension. In calculating the maximum tension for parallel cable assemblies, the number of conductors should be reduced by one (1). For assembled cables ("plexed") the "N" can be equal to the number of cables in the assembly, excluding ground wires. However, as an extra measure of safety, this number can also be reduced by one (1) – as noted in AEIC CG5-2005.

Example:

Calculate the maximum pulling tension for a 3-1/C pull using 500 kcm copper conductors in a parallel configuration:

$$T_{\max} = (0.011) \times (500,000) \times (2)$$
$$T_{\max} = 11,000 \text{ pounds (using eye)}$$

Calculated values are supplied in the following table.

Size	Pulling Eye Maximum Pulling Tension (lbs.)					
	Copper			Stranded Aluminum		
	1/C Single	3-1/C Parallel	3-1/C Triplex	1/C Single	3-1/C Parallel	3-1/C Triplex
8 AWG	181	362	543	132	264	396
7 AWG	229	458	687	166	332	498
6 AWG	288	576	864	209	418	627
5 AWG	363	726	1089	264	528	792
4 AWG	459	918	1377	333	666	999
3 AWG	578	1156	1734	420	840	1260
2 AWG	729	1458	2187	530	1060	1590
1 AWG	920	1840	2760	669	1338	2007
1/0 AWG	1161	2322	3483	844	1688	2532
2/0 AWG	1464	2928	4392	1064	2128	3192
3/0 AWG	1845	3690	5535	1342	2684	4026
4/0 AWG	2327	4654	6981	1692	3384	5076
250 kcm	2750	5500	8250	2000	4000	6000
300 kcm	3300	6600	9900	2400	4800	7200
350 kcm	3850	7700	11550	2800	5600	8400
400 kcm	4400	8800	13200	3200	6400	9600
450 kcm	4950	9900	14850	3600	7200	10800
500 kcm	5500	11000	16500	4000	8000	12000
550 kcm	6050	12100	18150	4400	8800	13200
600 kcm	6600	13200	19800	4800	9600	14400
650 kcm	7150	14300	21450	5200	10400	15600
700 kcm	7700	15400	23100	5600	11200	16800
750 kcm	8250	16500	24750	6000	12000	18000
800 kcm	8800	17600	26400	6400	12800	19200
900 kcm	9900	19800	29700	7200	14400	21600
1000 kcm	11000	22000	33000	8000	16000	24000

B. Cable grips

For cables pulled with a cable grip, the maximum tension should not exceed the value

shown in the following two tables, or the value calculated using the formula or table above, whichever is smaller (See following tables):

Type of Cable	Pulling Grips Maximum Pulling Tension (lbs.)			
	PE, XLP Insulated		EPR Insulated	
	Single Cable	Multiple Cables	Single Cables	Multiple Cables
Unshielded, with or without Jacket	2,000	2,000	2,000	2,000
Concentric Wire "URD" with Jacket	10,000	5,000	10,000	10,000
Concentric Wire "URD" without Jacket	10,000	5,000	6,000	3,000
Tape Shielded with Jacket	10,000	5,000	10,000	10,000
Fine Wire Shielded with Jacket	10,000	5,000	10,000	10,000
"LC" Shielded with Jacket	8,000	4,000	5,000	2,500
Polymeric Armored Cables (See Note 3)	-----	-----	10,000	10,000
Interlock Armor with PVC Jacket	5,000 [†]	-----	5,000 [†]	-----
Interlock Armor with Poly Jacket	5,000 [†]	-----	5,000 [†]	-----
Lead Sheathed Cables	See Subsequent Table			

[†] Interlock Armor pulling tension using pulling grips should be limited to the lesser of the value provided above or 50% of value of T_{max} , calculated using "Pulling Eye" formula.

NOTE 1: The above tensions for the multiple cables assume three cables in one grip (per AEIC CG5-2005). When using a grip, the stress on the cable conductor should not exceed 16,000 psi (0.013 lbs/cmil) for annealed copper conductors; 14,000 psi (0.011 lbs/cmil) for stranded $\frac{3}{4}$ and full hard aluminum conductors; and 10,000 psi (0.008 lbs/cmil) for solid $\frac{1}{2}$ to full hard aluminum conductors. For three single conductor cables in parallel and triplexed configurations, the allowable conductor stress should be based on two cables sharing the load.

NOTE 2: The pulling grip maximum tension values provided may not be suitable for cables by other manufacturers. As values may be lower for other manufacturers, it is recommended that the manufacturer of the cable(s) in question be consulted in regards to the mechanical limitations of the cable.

NOTE 3: Due to the higher sidewall bearing pressure capabilities of AirGuard[®] / Air Bag[®] cables, Prysmian recommends the use of pulling grips during installation. A combination pulling grip / pulling eye is an acceptable alternative method. Prysmian's Application Engineering department should be consulted (800.845.8507) for installations that have been designed with pulling eyes only.

Type of Cable	Pulling Grips Maximum Pulling Tension (p.s.i.)					
	PE, XLP Insulated		EPR Insulated		Paper Insulated	
	Single Cable	Multiple Cables	Single Cable	Multiple Cables	Single Cable	Multiple Cables
Lead Sheathed	16,000 (Note 4)	16,000 (Note 4)	8,000 (Note 5)	8,000 (Note 5)	1,500 (Note 6)	1,500 (Note 6)

NOTE 4: The maximum pulling tension stress limit for pulling grips on lead sheathed cable with XLPE/TRXLPE insulation is 16,000psi of lead sheath area for a single cable as well as one grip on three cables (per AEIC CG5-2005).

NOTE 5: The maximum pulling tension stress limit for pulling grips on lead sheathed cable with EPR insulation is 8,000psi of lead sheath area for a single cable as well as one grip on three cables (per AEIC CG5-2005).

NOTE 6: The maximum pulling tension stress limit for pulling grips on lead sheathed cable with Paper insulation is 1,500psi of lead sheath area for a single cable as well as one grip on three cables (per IPCEA P-41-412-1958).

Sidewall Bearing Pressure (Static Conditions)

To preclude damage to the cable from the dynamic radial pressure, which develops when a cable is pulled around a bend under pulling tension, this pressure must be kept as low as possible, and should not exceed the following values listed in the table. These values were calculated using the following formula.

$$P_{sw} = T_e \div B_r$$

Where:

- P_{sw} = Sidewall Bearing Pressure in pounds per foot of bend radius
- T_e = Pulling Tension as cable exits the bend (lbs)*
- B_r = Bend radius, in feet

*NOTE: The maximum pulling tension, as determined in above method(s) must be observed.

Sidewall Bearing Pressure (Dynamic Conditions)

Sidewall Bearing Pressure is also important in determining the minimum bending radii for DYNAMIC conditions, such as when the cable is being pulled under tension around a bend. To calculate the minimum bending radii for dynamic conditions, use the following formula:

$$MBR = (T_e \div P_{sw}) \times 12$$

Where:

- MBR = minimum bending radius (inches)
- T_e = Pulling Tension as cable leaves the bend (pounds)*
- P_{sw} = Maximum Sidewall Bearing Pressure in pounds per foot of bend radius from following table

*NOTE: The maximum pulling tension, as determined in above method(s) must be observed.

Type of Cable	Sidewall Bearing Pressure (lbs/foot of bend radius)*	
	PE, XLP Insulated	EPR Insulated
Unshielded, without Jacket	1,200	500
Unshielded, with Jacket	1,200	1,000
Interlock armor with PVC Jacket, Single Conductor & Three Conductor having round core (100% fillers)	800	800
Interlock armor with Poly Jacket, Single Conductor & Three Conductor having round core (100% fillers)	1,000	1,000
Concentric Wire, "URD", without Jacket †	1,200†	1,000†
Concentric Wire, with Encapsulating Jacket	2,000	2,000
Concentric Wire, with Sleeved Jacket	1,500	1,500
"LC" shielded with Jacket	1,500	1,500
Tape shielded with Jacket	1,500	1,500
Fine Wire shielded with Jacket	1,500	1,500
Teck-90 cable, Single Conductor & Three Conductor having round core (100% fillers)	800	800
Teck-90 cable, Three Conductor with minimal or no fillers	350	350
Lead Sheath (Solid Dielectric)	2000**	2000**
Polymeric Armored Cables	Air Bag®	2400
	AirGuard®	3000
Lead Sheath (PILC)	400	

† Value shown is for a single conductor cable pull. For a three-conductor pull, maximum Sidewall Bearing Pressure limits of 750 and 200 lbs. per foot, respectively, are recommended.

* The maximum pulling tension, as applicable for a pulling-eye or pulling-grip, must be observed in addition to the maximum sidewall bearing pressure limit.

**The values are based on the cross-sectional area of one lead sheath.

Note 1: Above values may not be suitable for cables by other manufacturers. As values may be lower for other manufacturers, it is recommended that the manufacturer of the cable(s) in question be consulted in regards to the mechanical limitations of the cable.

Special Consideration for Metallic Armored Cables

Sheath Currents and Voltages in Single Conductor Cables

In a single conductor cable with an interlocking armor, a voltage is induced in the concentrically applied wires of the grounding conductor as well as in the armor.

If the armor and the concentric grounding conductor are bonded or grounded at more than one (1) point, a current will flow in the completed path. The magnitude of the induced voltage is relative to the magnitude of the current in the phase conductor. The magnitude of the sheath currents (current flowing in the concentrically applied grounding conductor, plus current flowing in the interlocking armor) is a function of the induced voltage and the sheath impedance. Sheath currents can be large and can result in considerable heating of the armor and the concentrically applied grounding conductor. Coupled with the heat resulting from the passage of current through the phase conductor, the conductor insulation will be subjected to temperatures that may cause electrical failure or a serious reduction in the life expectancy of the cable.

If sheath currents are large enough to raise the temperature of the insulation above its rated value, it will be necessary to derate the cable unless steps are taken to eliminate them.

In a single conductor cable carrying currents less than 180 amps, (conductor size smaller than #2 AWG copper, 90°C rated insulation) sheath currents do not constitute a problem since induced voltages and sheath impedances are of the order to minimize sheath losses.

In single conductor cables carrying currents between 180 and 425 amps inclusive (conductor size #2 AWG to 250 kcm copper inclusive, 90°C rated insulation), sheath currents do not constitute a problem if the cables are spaced approximately one (1) cable diameter apart. At this spacing

the effect of mutual heating is minimized and at the same time the induced voltage is reduced by virtue of field cancellation effect at close spacing.

In single conductor cables carrying currents larger than 425 amps, (larger than 250 kcmil copper, 90°C rated insulation) it will generally be necessary to derate the cables in order to avoid overheating unless the sheath currents are eliminated.

Armor of magnetic material (such as galvanized steel) should not be used on single conductor cables intended for use in AC circuits. High inductive and magnetic losses will be incurred in such installations with consequent overheating of the cable.

Eliminating Sheath Currents

To prevent the flow of sheath currents, it is necessary to insure that all paths by which they may circulate are kept open. Cable armors and concentrically applied grounding conductors shall be bonded and grounded at the **supply end** only and thereafter isolated from ground and each other. Installing cables in individual ducts of insulating material, by using cables jacketed with PVC or other insulating material, or mounting cables on insulated supports, may attain isolation.

If the armors and concentrically applied grounding conductors are bonded and grounded at the **supply end** only through a non-ferrous metal panel and mounted on an insulating panel at the **load end**, no sheath current will flow. See the figure on the next page for an illustration of this technique.

a) Cables enter **supply end** enclosure through metallic non-ferrous panel (aluminum or other) in order to avoid overheating. Cable armors are bonded through panel.

b) Cable enters **load end** enclosure through panel of insulating material. The insulating material maintains the open circuit of the armors.

c) Cable armors and concentrically applied grounding conductors are bonded and grounded at the **supply end only**. When installed in this manner, the armor and concentric grounding conductor do not form a part of the system ground circuit and a **separate** ground conductor should be installed per the appropriate electrical code.

d) All cable connectors and lock nuts are of non-magnetic metal (aluminum or other).

Standing Voltage

When single conductor cables are installed per Figure below, an induced voltage will exist between ground and both the armor and the concentric grounding conductor throughout the length of the cable.



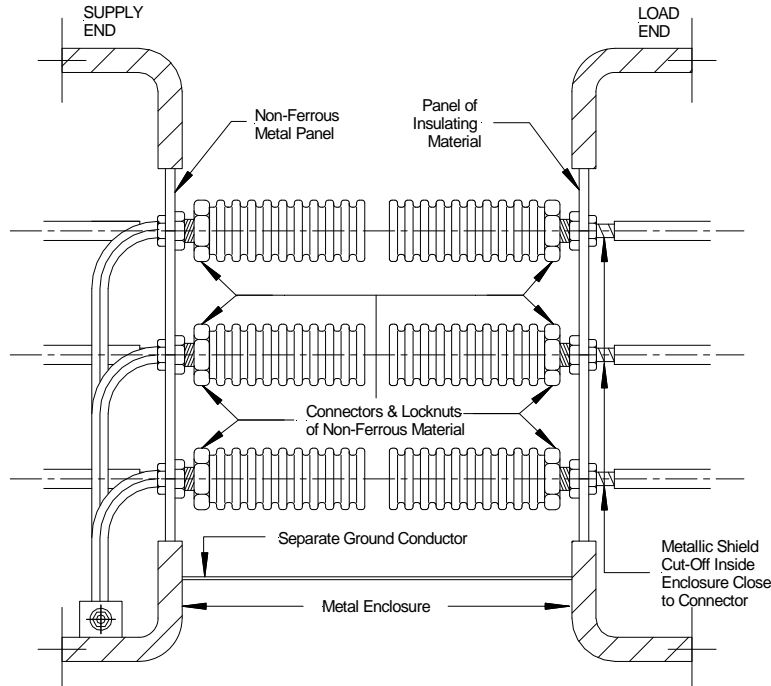

The magnitude of this voltage is proportional to the phase conductor current, the cable length and the spacing between the cables. The magnitude of the “standing voltage” is usually limited to about 25 volts. However, some Electrical Inspection Authorities limit this standing voltage to lower values.

One way to limit this standing voltage and at the same time increase the circuit length is to ground the armor and the concentric grounding conductor at the midpoint of the cable run. In this case, cable must go through a junction box at the midpoint of the run and must be connected on each side of the junction box as illustrated on the **supply end** of the Figure. In this particular case, the cables at both the supply and load ends must be connected through panels of insulating material in order to prevent the flow of sheath currents. However, when two (2) or more single conductor cables are installed in parallel per phase, this method of grounding at the midpoint of the cable run is not allowed. See diagram later in document for installation of single conductor armor cables in parallel.

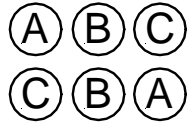
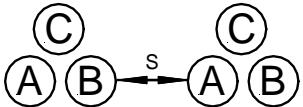
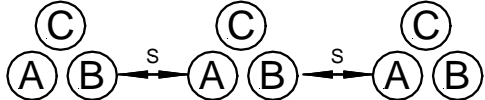

Installation of Single Conductor Cables in Parallel

Where several cables per phase are employed, symmetrical phase configurations should be used at time of installation in order to avoid current imbalance between the parallel legs of the same phase. The following are symmetrical configurations.

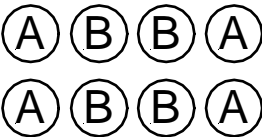
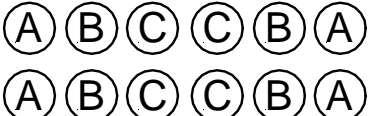
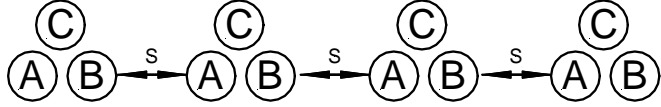
SINGLE PHASE	THREE PHASE
TWO (2) CONDUCTORS PER PHASE	TWO (2) CONDUCTORS PER PHASE
	 <p>OR</p>  <p>OR</p> 
THREE (3) CONDUCTORS PER PHASE	THREE (3) CONDUCTORS PER PHASE
NOT RECOMMENDED	
FOUR (4) CONDUCTORS PER PHASE	FOUR (4) CONDUCTORS PER PHASE
 <p>OR</p> 	 <p>OR</p> 

Notes:

1. S = Separation of groups. Equals width of one group.
2. Horizontal and vertical separation between adjacent cables should be a minimum of one cable diameter in order to take advantage of ampacity in free air in ventilated cable tray.
3. Neutral conductors can be located outside of the above groups in the most convenient manner.

REEL CAPACITIES

NEMA Method

The formula for calculating footage capacities of reels for round cable is shown as follows. A 5 percent factor and 95 percent traverse utilization have been built into the formula. Therefore, cables must be wound evenly to obtain uniformity, compactness and the nesting of successive turns and layers.

$$F = \frac{\pi}{12} \left\{ \left[B + \left(\frac{A - 2 \cdot X - B}{1.9 \cdot D} \right)^2 \cdot 0.95 \cdot D \right] \left[\frac{A - 2 \cdot X - B}{1.9 \cdot D} \right] \left[\frac{0.95 \cdot C}{D} \right]^2 \right\}$$

Round off the resultant down to nearest whole number.

- Where:
- F = Feet of cable on reel
 - A = Flange diameter, inches
 - B = Drum diameter, inches
 - C = Inside traverse, inches
 - D = Cable diameter, inches
 - X = Defined as distance between cable and the outer edge of reel flange. Clearance is equal to 1 inch or one cable diameter, whichever is the larger.

Note: The NEMA formula does not cover paralleled or triplexed assemblies. For maximum footages of these assemblies on a reel, consult cable manufacturer.

Handling of Cable Reels

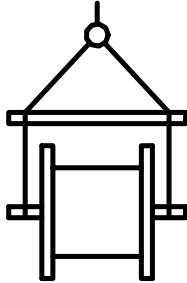
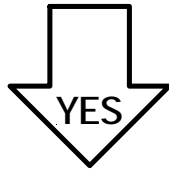

Reels should be lifted with a shaft extending through both flanges.

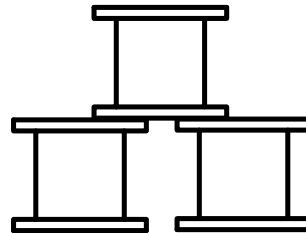
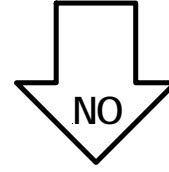

Inspect all reels. Reels laying flat should be refused or received subject to inspection.

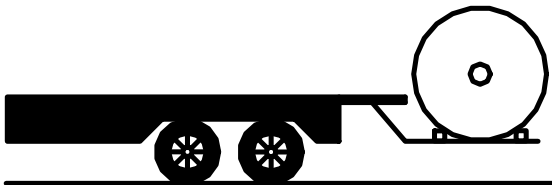

Reels should be lowered using hydraulic gate, hoist or forklift. LOWER CAREFULLY.

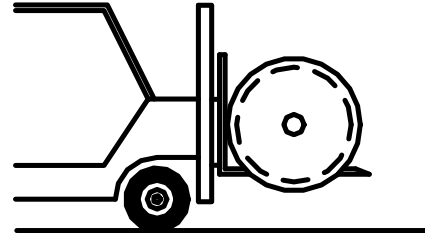

Do not allow forks to touch cable or reel wrap.

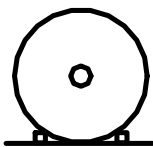

Load with flanges on edge and chock securely.

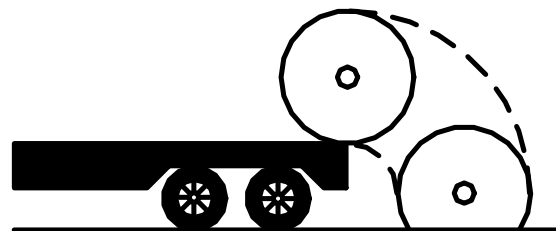

Never drop reels from trailer.

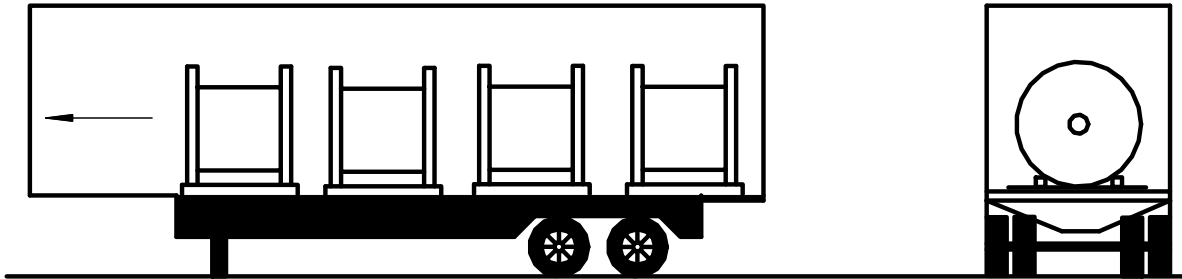

Shipment for unloading with a forklift at dock

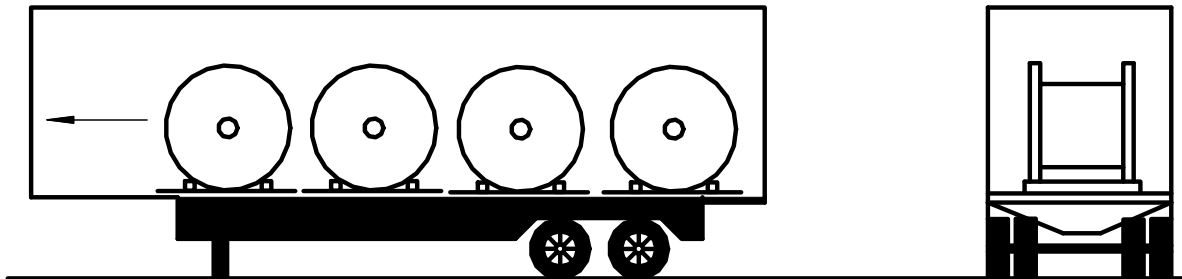

Shipment for unloading down an inclined ramp

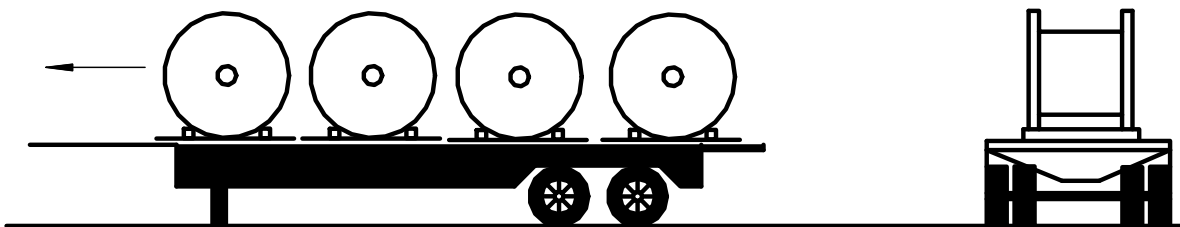

Shipment for unloading with a forklift at jobsite

Unloading from Open Flat Bed Trailers

CORRECT

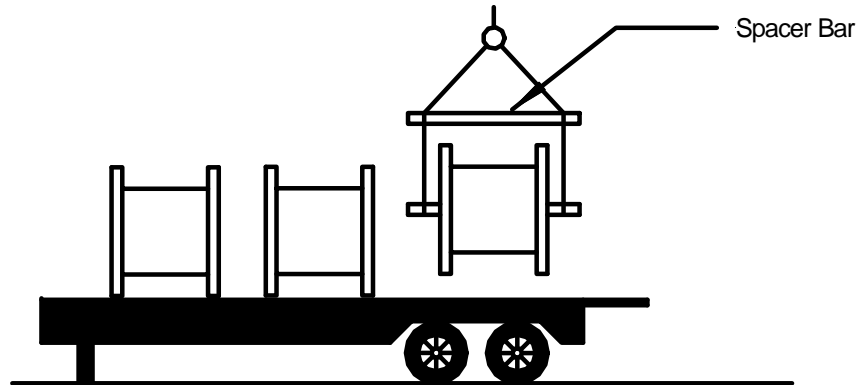

INCORRECT

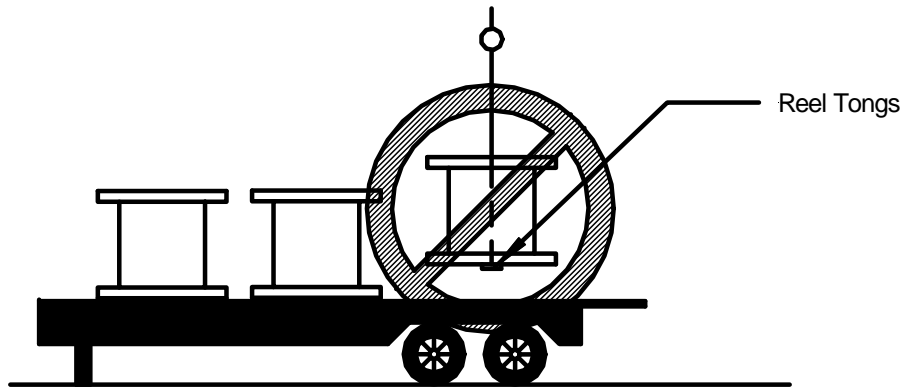

INCORRECT

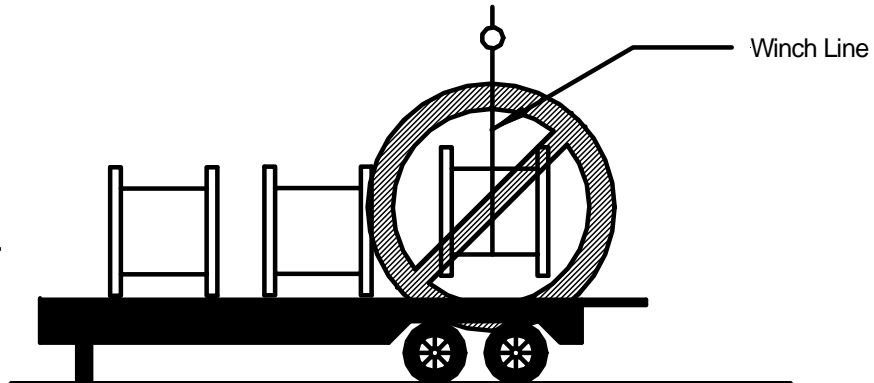

Cable Reel Handling

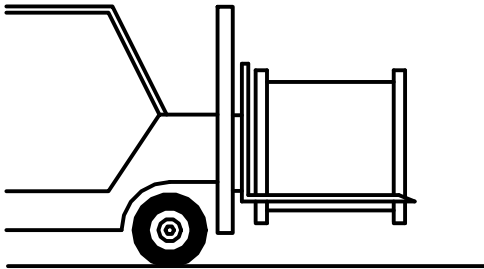

Do not allow forks to touch cable or reel wrap.

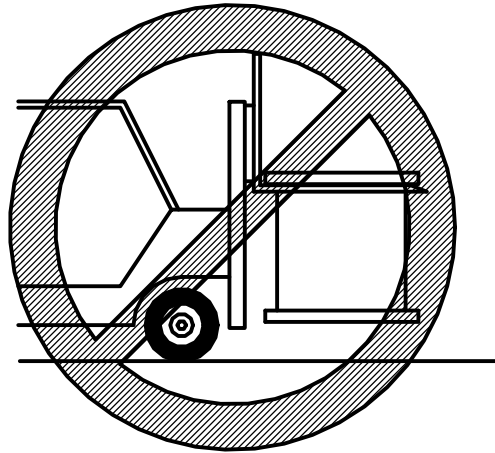

Do not allow forks to touch cable or reel wrap.

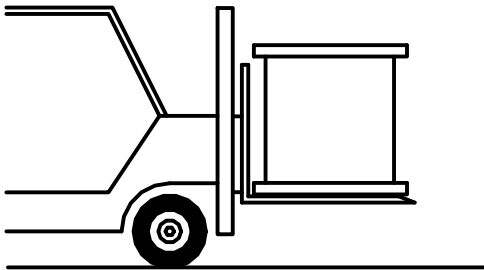

Do not allow forks to touch cable or reel wrap. This method OK for Low Voltage Cable only!

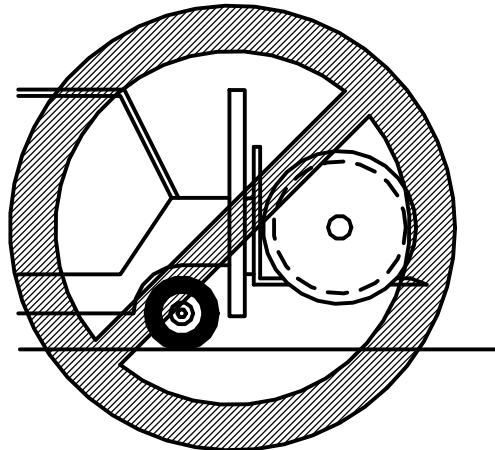

Do not allow forks to touch cable or reel wrap.